



ARCHIVED - Archiving Content

Archived Content

Information identified as archived is provided for reference, research or recordkeeping purposes. It is not subject to the Government of Canada Web Standards and has not been altered or updated since it was archived. Please contact us to request a format other than those available.

ARCHIVÉE - Contenu archivé

Contenu archivé

L'information dont il est indiqué qu'elle est archivée est fournie à des fins de référence, de recherche ou de tenue de documents. Elle n'est pas assujettie aux normes Web du gouvernement du Canada et elle n'a pas été modifiée ou mise à jour depuis son archivage. Pour obtenir cette information dans un autre format, veuillez communiquer avec nous.

This document is archival in nature and is intended for those who wish to consult archival documents made available from the collection of Public Safety Canada.

Some of these documents are available in only one official language. Translation, to be provided by Public Safety Canada, is available upon request.

Le présent document a une valeur archivistique et fait partie des documents d'archives rendus disponibles par Sécurité publique Canada à ceux qui souhaitent consulter ces documents issus de sa collection.

Certains de ces documents ne sont disponibles que dans une langue officielle. Sécurité publique Canada fournira une traduction sur demande.

CPRC

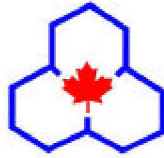

CCRP

CANADIAN POLICE RESEARCH CENTRE

CENTRE CANADIEN DE RECHERCHES POLICIÈRES

TR-10-91

On-Site Sampling and Detection of Drug Particulates

L. Elias and A. Lawrence
National Research Council

TECHNICAL REPORT
December, 1991

NOTE: Further information
about this report can be
obtained by calling the
CPRC information number
(613) 998-6343

NOTA: Pour de plus ample
renseignements veuillez
communiquer avec le CCRP
au (613) 998-6343



Executive Summary

This report is an extract from the book, "The Analysis of Drugs of Abuse", edited by T.A. Gough. The information provided in this technical report is useful material for the drug law enforcement officer. It presents where the drug detection is and where it is going.

The technology of drug detection today can be broken down into bulk detection techniques such as:

- X-ray imaging
- Gamma Backscattering
- Thermal Neutron Activation

The current air sampling techniques include:

- Acetone Vapour Detection
- Mass Spectrometry
- Gas Chromatography
- Ion Mobility Spectrometry

ON-SITE SAMPLING AND DETECTION OF DRUG PARTICULATES

LORNE ELIAS AND ANDRE H. LAWRENCE

National Research Council, Canada

10.1	INTRODUCTION	374
10.2	INSTRUMENTAL METHODS IN DRUG INTERDICTION	374
10.3	BULK DETECTION TECHNIQUES	375
10.3.1	X-ray Imaging	375
10.3.2	Gamma Backscattering	375
10.3.3	Thermal Neutron Activation	376
10.3.4	Other Systems	376
10.4	AIR SAMPLING TECHNIQUES	376
10.4.1	Acetone Vapour Detection	377
10.4.2	Mass Spectrometry	377
	10.4.2.1 Sciex/British Aerospace Systems	370
	10.4.2.2 Bruker/Bundeskriminalamt System	380
10.4.3	Gas Chromatography	382
	10.4.3.1 Portable Gas Chromatographic Detector for Cocaine and Heroin	382
	10.4.3.2 Scintrex System	388
	10.4.3.3 Thermedics System	389
10.4.4	Ion Mobility Spectrometry	389
	10.4.4.1 Principle of Operation	390
	10.4.4.2 Determination of Ion Signatures	393
	10.4.4.3 Concealment Detection Applications ..	394
	10.4.4.4 Medical and Health Applications	396
	10.4.4.5 Barringer System	397
10.5	CONCLUSIONS	398
	ACKNOWLEDGEMENTS	399
	REFERENCES	399

This report is an extract from the book, "The Analysis of Drugs of Abuse", edited by T.A. Gough. The information provided in this technical report is useful material for the drug law enforcement officer. It presents where the drug detection is and where it is going.

10.1 INTRODUCTION

The law enforcement officer plays a vital role in the battle against drug smuggling. Through careful inspection, intelligence, undercover operations and surveillance, customs and police officers worldwide manage to interdict tonnes of illicit drugs per year. However, because they are overwhelmingly outnumbered by their adversary, the quantity of seized drugs represents only a fraction of the total volume of the drugs trafficked. The fundamental objective of providing technical support to the law enforcement officer is to improve this situation.

The best-known detection aid used in customs work throughout many countries to search out narcotics is the so-called 'drugs' dog. Appropriately trained dogs can be an effective means of rapidly examining large quantities of baggage and searching in cramped quarters or inaccessible areas, inappropriateness for use near people, cost of training and the manpower requirement of dedicating one handler per dog. There are many well documented cases showing that dogs have been instrumental in uncovering shipments of *Cannabis* products, but success in finding heroin and cocaine is less frequent. Thus, while the presence of drug-detecting dogs at Customs border crossings and cargo terminals provides a public perception of reassurance (and possibly a measure of deterrence), there is clearly a need for additional technical support.

Accordingly, there has been interest and a steady growth in research and development in the field of instruments for the detection of illicit drugs.

Government agencies in several countries are undertaking research programmes aimed at the development of electromechanical instrumentation to complement existing procedures for the detection of drugs. A number of law enforcement agencies and government research institutions are collaborating at the national and international level on the sharing of costs, results and benefits of the efforts.

10.2 INSTRUMENTAL METHODS IN DRUG INTERDICTION

One immediate advantage which any instrument is seen to have over the detector dog is continuous availability. Such equipment should also be highly sensitive

and selective towards drugs, easy to use by non-scientific field personnel with a minimum of training, portable, require little maintenance and be inexpensive in capital outlay and running costs. Such equipment should be seen in the context of aiding an officer in his or her work, whilst in no way devaluing or substituting for traditional skills.

Various detection techniques have been tried over the past 15 years or more. Many of these have been based on existing equipment used for other purposes, e.g. detectors used in gas chromatography. None have fully met the requirements of the law enforcement community, although some commercially available drug detection systems have met with limited success. There may, of course, be no single 'black box' solution to the problem, because of the very wide variety of situations in which drugs are smuggled. Devices for detecting drugs in mail are unlikely to be directly applicable for use in screening hand baggage or containerised cargo. Different devices will be required for different situations.

Instrumental methods of detecting concealed drugs may be categorised under two main headings, bulk detection techniques and air sampling techniques, and these are discussed in the following sections.

10.3 BULK DETECTION TECHNIQUES

In bulk detection techniques, suspect items to be examined are subjected to electromagnetic or ionising radiation, and the presence of drugs is determined by the interaction of the bulk content of the item with the probing field. Bulk detection techniques include X-ray imaging, γ -backscattering, thermal neutron activation (TNA), nuclear magnetic resonance (NMR) spectroscopy and dielectric analysis.

10.3.1 X-ray Imaging

The use of X-radiation in security applications is an established technology that continues to be improved and upgraded. Present generation X-ray equipment features lower doses and finer image resolution than earlier models. Recent innovations in detector arrays coupled with colour enhancement techniques have enabled the distinction to be made between organic and inorganic materials on the viewing screen. Notwithstanding these technical advances, X-rays provide little in the way of a distinguishing signal for narcotics. However, X-ray systems are a useful first line of defence in screening applications and are routinely used by some customs authorities.

10.3.2 Gamma Backscattering

Apart from X-ray imaging, only the technique of γ -backscattering has been engineered into commercially available instrumentation, which is in current field

use. Essentially a hydrogen detector, the device, in the form of a compact, hand-portable unit, can be used to detect drugs in sealed metal containers but not in wooden, cardboard, plastic or other hydrogen-rich enclosures.

10.3.3 Thermal Neutron Activation

Thermal neutron activation (TNA) technology has been developed largely for baggage screening at airports to detect explosives. With this system, checked baggage is subjected to irradiation from a low energy neutron source, such as californium. The neutrons react with nitrogen nuclei to produce characteristic γ -rays, which are monitored. The system is capable of processing baggage at the rate of ten per minute. Although being considered for use as a narcotics detector, some of the drawbacks that have hampered its acceptance as an explosives detector are likely to prevail in adapting TNA for narcotics, e.g. the high background signal from common nitrogenous materials (wool, leather, plastics, etc.), high capital and operating expenditure, the very considerable floor space requirements and the risk of residual radioactivity.

10.3.4 Other Systems

Feasibility studies on the efficacy of NMR (see Chapter 7) have been undertaken. NMR, also investigated for its applicability to explosives detection, suffers from susceptibility to metallic interference and the very high cost of the equipment. Little progress has been reported in the development and use of the dielectric analysis technique since the initial effort. Acoustic detection, which measures the difference in absorption and reflection of sound waves by various materials, has been investigated. Thermal imaging has been applied to the detection of concealed packages on the person and in containerised cargo.

10.4 AIR SAMPLING TECHNIQUES

These are based on the chemical analysis of air samples obtained from within, from the exterior surface or from the vicinity of a suspect item, to determine trace amounts of drug-related constituents. These constituents may be present in the form of vapours or microscopic particles. To date, at least five air sampling/chemical sensing techniques for drug detection have been developed and become commercially available. These are based on:

- (i) thermionic/acetone detection;
- (ii) mass spectrometry;
- (iii) gas chromatography with nitrogen-selective detection;
- (iv) gas chromatography with chemiluminescent detection;
- (v) ion mobility spectrometry.

In the following sections, we describe in some detail these chemical ‘sniffing’ technologies, their development and examples of field experience associated with them.

10.4.1 Acetone Vapour Detection

Cocaine and diamorphine, particularly in salt form, exhibit such low vapour pressures as to render them virtually undetectable by vapour sampling techniques outside the laboratory setting. Acetone is used as a solvent in the refining of cocaine and heroin and trace amounts are almost invariably detected in these products at importation. It was reasoned, therefore, that acetone, with its high vapour pressure and ease of permeation through plastic wrapping material, could serve as a suitable indicator of concealed narcotics. This observation led to the development in the USA of an acetone detector derived from a commercially available refrigerant leak sensor.

The on-line detection of acetone vapour in air was achieved in a novel process based on chlorination of the vapour followed by thermionic sensing. In this process, the air stream to be sampled is first mixed with chlorine gas, fed into a high-temperature reaction chamber to effect the chlorination of organic vapours present (such as acetone and ethanol), then scrubbed clean of excess inorganic material before entering the sensing cell of the detector. The sensor, which contains an alkali metal (rubidium) source heated to a high temperature, responds preferentially to the presence of organochlorine compounds, generating a current between the electrodes of the cell.

The acetone vapour detector was incorporated into passenger screening portals at the customs clearance areas at international airports in the USA and the UK on a trial basis. The portals, similar in appearance to the metal detecting doorways used in security screening, were equipped with a vertical array of fans on one side to create an air curtain which swept across the passenger to probes on the opposite side. These probes led to an array of acetone detectors. The system was credited with contributing to a few drug seizures and in acting as a highly visible deterrent. However, the widespread occurrence of acetone in the environment and hence lack of selectivity for drugs led to too many false-positive responses for the system to be adopted on a widespread basis.

10.4.2 Mass Spectrometry

Limited versatility, as in the case of the thermionic detector, is not a shortcoming generally associated with mass spectrometry (MS). On the contrary, MS is often viewed as the single, most universally adaptable instrumental technique for the identification of unknown substances (see Chapter 5). In addition, MS features high sensitivity and a rapid response time. Advantages such as these have prompted a

number of research and development efforts on the application of MS based systems for illicit drug detection. Two commercial developments are reviewed below.

10.4.2.7 Sciex/British Aerospace Systems

The MS system manufactured by Sciex (Canada) under the name TAGA (trace atmospheric gas analyser) has been used in field studies with a number of customs authorities. Early work concentrated on evaluating the TAGA for the detection of traces of organic vapours in the atmospheres of cargo containers in which drugs could be concealed. Work concentrated on identifying vapours of organic compounds which were associated with heroin and cocaine.

The instrument used in this investigation incorporated a number of innovations designed to convert MS from laboratory usage to real-time air sampling in the field. It consisted of a single quadrupole mass analyser and an atmospheric pressure chemical ionisation (APCI) source. The TAGA was capable of sampling ambient air at flow-rates in excess of 500 l min⁻¹, thereby lending itself to the high volume monitoring requirements of cargo containers.

Ionisation of the sample stream in the TAGA APCI source is effected by a corona discharge, which can be operated to yield positive or negative reactant ions. The chief reactant positive ions produced in ambient air are the proton hydrates, H₃O⁺(H₂O)_n, while the main negative ions are O₂⁻ and the clusters O₂⁻(H₂O)_n and O₂⁻(O₂)_n. Ionic reactions with traces of the target molecules T (from heroin, cocaine, amphetamine, *Cannabis*, etc.) can result in the formation of charged cluster ions, as in the following proton charge-transfer mechanism:

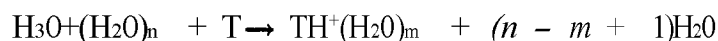

To minimise the complexity of the spectra, ions produced in the APCI source are passed through a declustering lens prior to their entry into the quadrupole mass filter. In the lens region, under the combined effects of a dry nitrogen stream and an electric field, the water clusters are stripped away, leaving the protonated parent ion TH⁺. The high sensitivity of the TAGA for atmospheric analysis is due in part to the open source design, which allows direct access to ambient air, and the coupling of the source declustering region to the quadrupole through a relatively large (100 μm) orifice, which results in high ion transmission.

Two modes of air sampling (on-line and 'off-sensor' sampling) were employed in the Sciex studies. In the first mode a flexible heated PTFE pipe, ca 3 cm in diameter and 10 m long, was connected to a high-volume suction pump through an opening in the wall of the cargo container under test. The line was used to sample the headspace volume of the closed container. In the other mode, a hand-held air sampling probe with an adsorbent filter for preconcentrating trace amounts of the target chemicals was used to sample around the boxes and crates inside the container. Following sample collection, the adsorbent cartridge was removed

from the probe and inserted in an inlet arm of the MS, where it was heated and purged with a carrier gas stream to transfer the collected vapours to the ion source. The long sampling line of the former method proved ineffective for transporting vapours other than those of solvents and volatile breakdown products. Drugs *per se* were detected more satisfactorily using the off-sensor probe. The probe, on the other hand, concentrated many chemicals in addition to those of interest, which tended to interfere with the analysis, causing a significant number of false alarms.

However, by far the most revealing and important result to emerge from this study was the observation that, while the detection of drug vapours was beyond the practical lower limit of detection of the system, microscopic particles of cocaine and heroin, which are frequently found on the exterior surfaces of the polyethylene bags in which the narcotics are packaged, could be aspirated, vaporised and detected. A development programme to improve the sampling process for drug particles and vapours and at the same time to improve the specificity of the TAGA system then followed.

An order-of-magnitude improvement in specificity was realised by recourse to tandem mass spectrometry (MS-MS) (see Section 5.2.5), which Sciex refers to as its Aromic system. This is the basis of the analytical component of the mobile contraband detector which is marketed by British Aerospace (UK) and known as Condor. The Aromic system, represented schematically in Figure 10.1, couples two quadrupole mass filters in series, interconnected by a reaction region. The first quadrupole Q_1 is used to select the parent ion of the target compound produced in the APCI source; the parent ion undergoes collision-induced fragmentation in the reaction region R_c , and the daughter ions so formed are detected by means of the second mass analyser Q_2 . Cocaine, for example, yields a protonated parent ion at m/z 304. While the probability of a chemical species other than cocaine having the

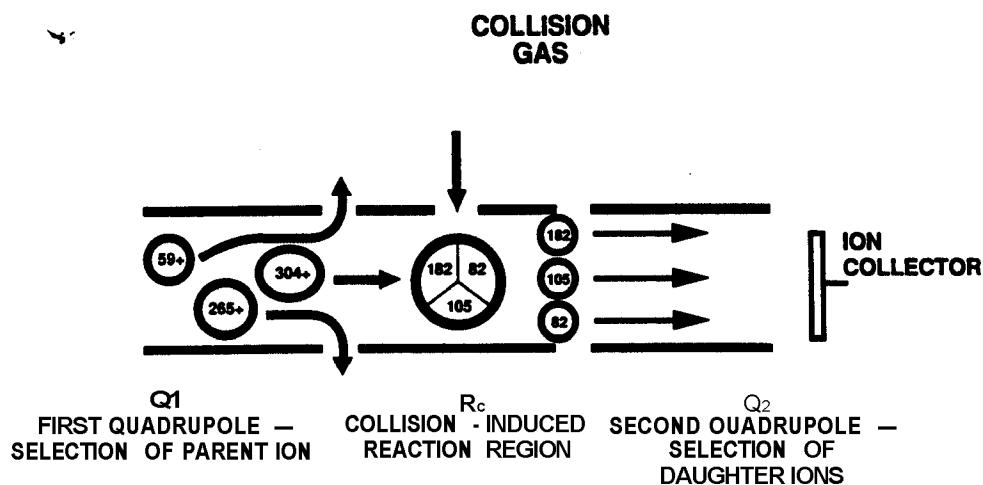

Figure 10.1. Schematic diagram of Sciex Aromic system. Reproduced with permission

same m/z value is not high, the probability of that species also giving rise to the same daughter ions as those observed with cocaine (m/z 182, 105 and 82) is even lower.

Sample acquisition in the Condor proceeds by drawing air through a probe equipped with a rotating brush head and fine dust trap. The probe is connected through a long, flexible hose to a powerful suction pump sampling at the rate of 1500 l min^{-1} . Used like a vacuum cleaner, the probe is passed manually over the cargo surfaces. In situations where the cargo to be screened is beyond the reach of the Condor vacuum line, a battery-operated aspirator pump with a similar probe head is used. Particulate matter is swept into the air flow and filtered out by the dust trap, which consists of three discs of very fine quartz mesh held along the upper bar of a flat, T-shaped cartridge. The quartz discs also serve as preconcentrators of heavy polar organic vapours, each disc being chemically treated to provide different adsorption characteristics. After sampling, the cartridge is removed from the probe head and inserted in a desorption carousel attached to the Atomic unit. Each disc is sequentially heated in the carousel to a specific temperature (depending on the boiling point and thermal lability of the target) by a stream of hot gas, which vaporises the collected material and permits analysis.

A small portion of the sampled air which passes through the quartz elements is fed directly into the ion source for analysis of volatile, non-particulate target compounds (such as acetic acid, acetone, diethyl ether, methyl benzyl ketone and methyl benzoate), although the studies have shown that these compounds are not sufficiently characteristic to serve as fingerprints for drugs, in the absence of other information.

The equipment is programmed to detect over 20 different drugs and by-products in both particle and vapour form. Threshold levels of detection can be varied and it is capable of detecting compounds at the picogram level. Background subtraction of potentially interfering materials is also available.

Despite this level of sophistication, various trials have shown that the system does give false-positive and false-negative results and this needs to be addressed in further developments. As with other detection systems, there is a need to improve significantly the sample collection equipment. There are a small number of Condor systems in operational service with customs authorities, and their experience will be the real test of the efficacy of the system.

10.4.2.2 Bruker/Bundeskriminalamt System

The Model MM-1 mass spectrometer marketed by Bruker-Franzen Analytik is a rugged, multi-purpose instrument which can be mounted in a small van for mobility. Originally researched at a federal government laboratory of the Bundeskriminalamt (BKA) in Germany, the Bruker mass spectrometer is basically a single quadrupole instrument with an electron impact (EI) source having features designed to optimise it for field operation. For the detection of concealed drugs, the MM-1 relies, like

the Condor, on the presence of drug residues on the exterior of the item to be screened.

The mass filter of the MM-1 is a monolithic, hyperbolic quadrupole, the construction of which ensures stable alignment of the pole faces, while the ion source makes use of dual filaments for extended life. To alleviate the problem of signal extraction with EI mass spectra in the analysis of complex mixtures as encountered in surface sampling, a quartz capillary column is interfaced with the MS to serve as a sampling line and to provide gas chromatographic (GC) separation of the sample constituents.

A diagram of the Bruker system is shown in Figure 10.2. In this configuration for surface sampling, the head of the quartz sampling line consists of a heated nickel mesh housed in a steel bellows, which, when pressed against the test surface, promotes vaporisation of any drug particles present. The vapours pass through the silicone membrane and are drawn through the capillary column. The column is temperature programmed and uses ambient air as carrier gas. The MS inlet is a silicone membrane separator, reinforced by a nickel screen to withstand atmospheric pressure.

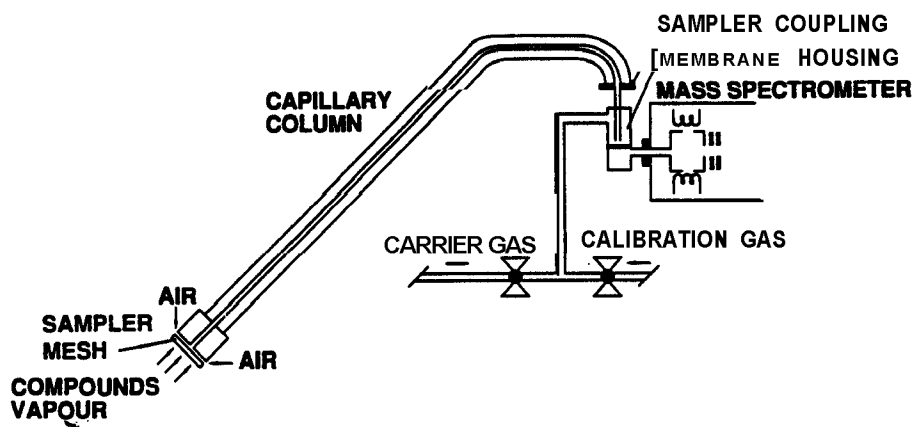

Figure 10.2. Schematic diagram of Bruker MS system. Reproduced with permission

The MM-1 also provides the option of sampling remote from the analyser, by means of a separate battery-powered air pump fitted with a fine nickel mesh filter. The mesh is in the form of a long ribbon, which is rolled from one spool to another, much like a tape cassette, exposing fresh surface for each sampling.

While the detection limit of the MM-1 in realistic settings (ca 50 ng for cocaine) is probably adequate, difficulties with specificity are inherent in performing trace organic analysis of complex mixtures using EI ionisation. Owing to fragmentation of the target compounds and possible overlap with similar fragments from non-target compounds, repetitive sampling and a good measure of interpretive skills on the part of the operator are required in order to avoid an undue level of false

alarms. The system has been subjected to field trials at an international airport and further development work is in progress.

10.4.3 Gas Chromatography

For field use, the time-dependent nature of the CC analytical process (see Chapter 2) would appear to be incompatible with the requirements of customs operations for an almost instantaneous result. Nevertheless, this well established technique offers several distinct advantages for drug detection over the so-called real-time detectors, such as the acetone sensor and MS systems described in Sections 10.4.1 and 10.4.2. GC-based detectors in general are sensitive, reliable and relatively maintenance free, and can be highly selective.

The following section describes a research and development programme undertaken by the authors which culminated in the production of the first commercially available, portable GC trace narcotics detector.

10.4.3.1 Portable Gas Chromatographic Detector for Cocaine and Heroin

The National Research Council (NRC) maintains a research programme on the development of air sampling methodology and the adaptation of sensitive laboratory analytical techniques for field use. GC-based 'sniffers' have been designed to sample and detect traces of target chemicals in a variety of field scenarios. In contrast to more elaborate instruments designed for the complete analysis of complex mixtures, these 'sniffers' are dedicated, portable devices intended for a few specific compounds of interest. An underlying feature of the NRC technique is the use of air sampling with solid adsorbents to preconcentrate the vapours, with subsequent thermal desorption. The technology finds application in such areas as the monitoring of pesticide drift from spray operations [2], measurement of atmospheric fluorocarbon concentrations [3] and the detection of hidden bombs on aircraft [4].

In response to a request from Canada Customs, a project was undertaken by the NRC aimed toward the development of a GC method to detect cocaine and heroin in mail. The Canada Post Corporation Act (1981, 1982, 1983) prohibits customs inspectors from opening first-class letters below a specified weight and the international mail service in Canada could therefore be a vulnerable route for drug trafficking. Initial research and development efforts were therefore focused on the detection of drugs concealed in letter mail. Earlier attempts at drug detection using high-resolution GC with flame ionisation detection (FID) were thwarted by excessive background interference from the many organic compounds in the environment. With the advent of nitrogen-specific detectors, this background problem was minimised, and GC detection of narcotics was considered feasible.

10.4.3.1.1 Vapour pressure measurements As an initial and integral step of the GC 'sniffer' project, measurements were carried out to determine the vapour pressures of cocaine and diamorphine (and amphetamine) in pure base form. In this procedure, a dynamic vapour source was used to generate controlled vapour concentrations of the drugs in an air stream, which were subsequently analysed. A purified air stream (up to 100 ml min^{-1}) was saturated with the vapour of interest, by passing it over 250 mg of test sample held in a thermostated U-tube. The vapour was collected using glass adsorption tubes and analysed by thermal desorption and GC. Equilibrium vapour concentrations for cocaine and diamorphine were generated at various temperatures (up to 66°C) and the data were plotted as $\log P$ vs $1/T$ according to the equation:

$$\log P = A - B/T \quad (10.1)$$

where P is the vapour pressure in Torr and T is temperature in Kelvin. The values of the constants A and B are 13.02 and 5884, respectively, for cocaine and 16.20 and 7549, respectively, for diamorphine. At 20°C the equilibrium vapour pressures were calculated to be 8.7×10^{-8} Torr for cocaine and 2.7×10^{-10} Torr for diamorphine. Under the same conditions, the vapour pressure of amphetamine was 0.24 Torr [5].

The low vapour pressures of cocaine and diamorphine, coupled with the attenuation in vapour emission due to packaging and concealment, pointed to extreme difficulty in relying on vapour-only analysis to detect hidden drugs. However, in the course of conducting a preliminary laboratory study simulating the smuggling of cocaine in letter mail, traces of drugs in the form of microscopic particles were found to be transferred to the exterior of the packages. This observation served to direct our efforts to take advantage of the phenomenon by sampling for drug particulates around a suspect object.

10.4.3.1.2 Sample acquisition technique A narcotics 'sniffer' should be capable of collecting and analysing quickly and accurately the characteristic vapours emanating from illicit drugs. The volatile species identified in the headspace of drugs include organic compounds arising from decomposition products and the drug manufacturing process.

Although it is possible, in principle, to detect drugs via their decomposition products and other trace impurities, past experience had shown that this is not selective and, therefore, not sufficiently reliable. The difficulties in using acetone as a marker for cocaine have been cited above. Similarly, acetic acid, which is commonly encountered with heroin, is also used as a solvent in, for example, the plastics, food, dye and printing industries. Consequently, the approach adopted in this work focused on the detection of the parent drug molecules, rather than on trace contaminants.

A sample acquisition technique was developed based on the aspiration and

trapping of micrometre-size particles (and also vapours) on a platinum filter, then subjecting the filter to GC analysis. The sampling cartridge consisted of a steel tube (3 mm in diameter x 7 cm in length) containing platinum gauze [6]. In some experiments, the filter was coated with a thin film of silicone gum, prepared by dipping it into a solution of 0.5% OV-17 in chloroform. For sampling, the cartridge was connected to the inlet port of a hand-held probe and battery-operated air pump. The probe was swept across the surface of the suspect item while air was drawn through it at 1 l min^{-1} for about 10 s. The sampling cartridge was subsequently removed from the probe, connected to a carrier gas line and inserted into the heated inlet of the GC analyser. The probe and analyser together constitute the two components of the NRC Trace Narcotics Detector (TND) system.

10.4.3.1.3 Gas chromatographic analyser This consists of a microprocessor-controlled GC equipped with a packed nickel column (3% OV-1 on Chromosorb) operated isothermally at $190\text{ }^{\circ}\text{C}$ and a nitrogen-phosphorus detector (NPD). The NPD was found to be the most specific detector for the GC analysis of cocaine and heroin among the various detectors tested, including electron-capture (EC) and photoionisation detectors. Retention times for cocaine and diamorphine were *ca* 30 and 90 s, respectively. A refillable carrier gas cylinder housed in the instrument provides up to 24 h of continuous operation.

A novel one-stage, thermal desorption injection port (shown schematically in Figure 10.3) is incorporated in the TND. This port, which is heated to $220\text{ }^{\circ}\text{C}$, allows the rapid and precisely controlled injection of the sample as a narrow plug of vapour, comparable to conventional GC injections. In the standby mode a spring-loaded valve provides sealing against the atmosphere while carrier gas flows to the column. In the analytical mode the sampling tube is first connected to an auxiliary carrier gas line on the front panel of the instrument and then inserted into the inlet port. This automatically opens the spring-loaded valve, shuts off the main carrier gas supply and initiates the signal processing. The description, operation and performance of the injector have been published in detail previously [6,7].

The NPD uses an electrically heated, rubidium-doped ceramic bead. In addition to the carrier gas, which may be either nitrogen or helium, the bead requires hydrogen and air for proper operation. In normal laboratory use these gases are obtained from compressed gas cylinders. With a field instrument, however, it is desirable to avoid the additional weight and explosion hazard associated with a separate hydrogen cylinder. To this end, a carrier gas mixture of 4% hydrogen in nitrogen is used.

Air to feed the NPD is taken from the atmosphere by means of a diaphragm pump and passed through a charcoal filter at 150 ml min^{-1} . The detector response is similar to that observed using high-purity compressed gases.

The TND is equipped with a membrane-style keyboard with sealed switches and a 512×256 graphics electroluminescent display. All instrumental functions and signal processing are under microprocessor control. An algorithm has been

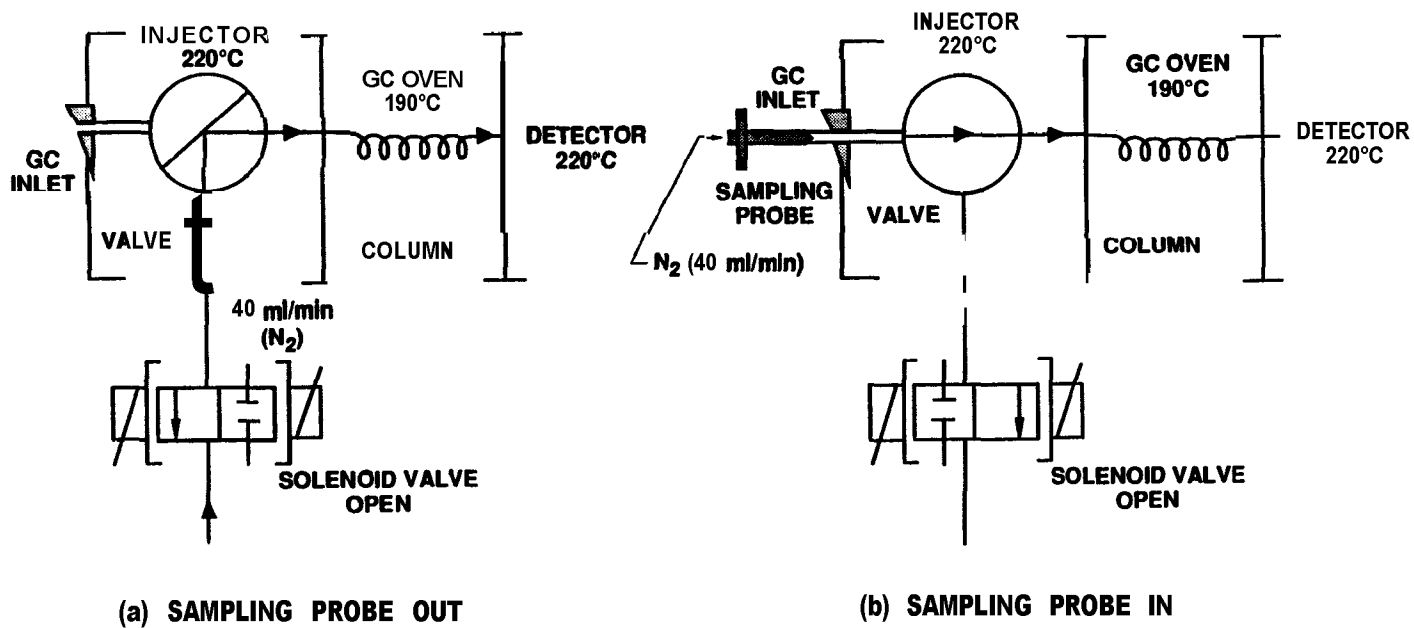

Figure 10.3. Schematic diagram of the TND single-stage injection port

developed which allows peak recognition in the appropriate retention 'windows.' The readout displays the analytical results in terms of HIT (positive) or NONE (negative) for each of the target drugs. In addition, an auxiliary signal output can be connected to a strip-chart recorder to provide a hard copy of the chromatogram. Typical chromatograms from sampling test letters containing cocaine and heroin are shown in Figure 10.4. The total cycle time of the TND for the concurrent detection of cocaine and heroin, including sampling, is about 3 min.

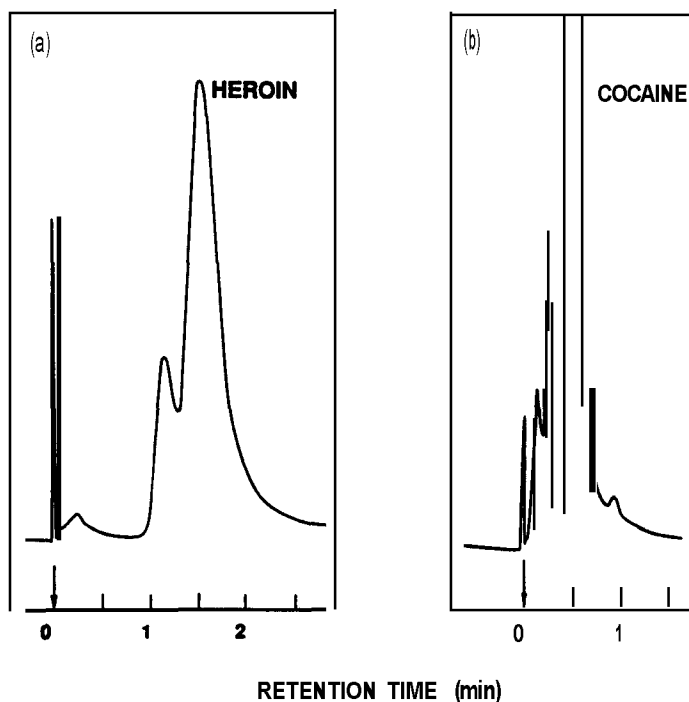

Figure 10.4. Gas chromatograms from sampling test letters

The chromatographic system is calibrated by depositing 1-2 μl of cocaine or diamorphine solution ($10\text{-}20 \text{ ng } \mu\text{l}^{-1}$) on the tip of the sampling cartridge and analysing the standards in the same manner as an air sample.

10.4.3.1.4 Laboratory validation tests A series of laboratory tests were conducted in cooperation with a number of federal law enforcement groups to provide an initial evaluation of the TND. About 200 letters were prepared, eight of which were spiked with gram amounts of cocaine or heroin packaged in a variety of ways simulating those encountered in actual case incidents. The remainder of the letters contained similar amounts of different chemical substances to study possible interference effects.

All letters were sampled using the probe and single-stage desorption system described above. The detailed description of the packaging and sampling and the results of the analyses have been reported previously [8]. The most significant findings of these tests were as follows:

- (i) the overall rate of correct identification exceeded 75%;
- (ii) no false positives were observed;
- (iii) the majority of blank or innocent letters yielded baseline chromatograms;
- (iv) responses were obtained to some of the letters containing potential interfering chemicals, but their retention times did not coincide with those of either cocaine or diamorphine.

These laboratory tests further demonstrated that detectable amounts of drug are often present on or near the surface of suspect items, probably as a result both of small pinhole openings in the packaging and from handling the drug during packaging.

10.4.3.7.5 TND field trials In collaboration with Canada Customs, a field study was carried out at an international mail office, where about 60 suspect letters, selected for secondary examination, were screened using the sampling technique described above. Most of these letters were from southeast Asia and South America. No hits or spurious signals were obtained from any of these letters, whereas a positive heroin signal was obtained from a spiked letter included in the tests for control purposes.

Although the results from this relatively small sampling of letters agreed with the expectations of the customs examining officers, there could be no confirmation that drugs were absent short of opening the letters, a practice prohibited under Canadian law.

Letters may be opened for inspection in the USA and, accordingly, arrangements were made with the US authorities to conduct a more extensive field trial. A total of 246 pre-screened letters were examined using the TND and no false readings, either positive or negative, were observed. Three letters yielded positive cocaine signals and were later confirmed to contain the drug. The remaining 243 mail items were subsequently shown by manual inspection to contain no drugs, thus supporting the observations made using the TND.

The results of the laboratory and field trials indicate that the TND is capable of detecting nanogram amounts of the drugs, equivalent to a concentration of about 1 part in 10^9 (mole fraction) in the volume of air sampled. The TND is also highly specific, with a false alarm rate approaching zero for letter screening. A number of modifications and improvements were identified, such as extending the range of applicability of the TND to the detection of a wider range of nitrogenous drugs, particularly other opiates and amphetamines. Although not appropriate to high-throughput screening, the TND is useful for the spot checking of suspect items.

10.4.3.1.6 Baggage screening Two trials were carried out to determine the suitability of using the TND to screen baggage at international airports and border crossings. In these experiments, the TND was programmed to detect only cocaine.

The first open test was conducted in conjunction with two Canadian law enforcement agencies. Three suitcases filled with clothing and other items were used. Approximately 0.5 kg of illicit cocaine was placed in each of two suitcases, with the third as a control. The contraband was sealed in a plastic bag and the bag was wrapped in brown paper, bound with cellophane tape and further secured with rubber bands. The suitcases were sampled before and after spiking with cocaine. One set of sample cartridges was analysed immediately using the TND, while the remaining replicate set was saved for analysis by ion mobility spectrometry (IMS), which was performed later in the laboratory (see Section 10.4.4.3). The incidence of false alarms from the TND (both positive and negative) was higher than that in the screening of letter mail.

The second test was conducted at an international airport. Sixty pieces of luggage were sampled on site and analysed with the TND. Blanks and standard cocaine solutions were periodically run to ascertain that the TND was performing satisfactorily. No drugs were detected, but valuable information was obtained with regard to interferences and memory effects. The incidence of false alarms was again higher than that encountered in the screening of letter mail. Also, during the course of the testing, a few incidents occurred where an excessively large sample of innocuous material contaminated the instrument, producing 'ghost' peaks and overloading. It was concluded that a two-stage thermal desorption configuration with a clean-up step is necessary for the sampling of large surfaces such as baggage, vehicles and cargoes.

Throughout the various phases of the research and field tests, a general level of confidence in and acceptance of the TND technology has been expressed by law enforcement officers, the ultimate users of the equipment. Moreover, extensive co-operation and valuable input was received from the customs inspectors on a number of modifications aimed at furthering the performance and enhancing the efficacy of the TND in the field.

Work is in progress at NRC to extend the range of capability of the TND to non-letter mail situations. At the same time, TND technology has been transferred to Scintrex (Canada) for production, and the company has introduced a number of significant modifications.

10.4.3.2 Scintrex System

In the Scintrex Model TND-1000, a two-stage sample injection technique is employed, in which particulates collected on the first-stage filter are vaporised and transferred to a smaller second filter, from which they are flash heated and injected into the GC column. The first stage consists of a disc of 100 mesh metal gauze, about 4.5 cm in diameter, in a rectangular plastic holder. Used with a hand-carried

impeller pump, it permits relatively high-volume air sampling, with flow-rates of a few hundred litres per minute. Much of the lower boiling extraneous material trapped on the first-stage filter is vented during the transfer to the second stage (albeit at the expense of some loss of the target compounds), thereby extending the areas of application beyond those suited to the previous single-stage design. The analysis time for cocaine and heroin is 2 min.

A compressed gas supply of 6% hydrogen in nitrogen is used, but the instrument can alternatively operate from an internal hydrogen generator and purified ambient air.

Field experience with the instrument has included use by law enforcement and prison service agencies. Cocaine has been detected in a number of simulated and real-life smuggling and dealing situations, e.g. in rooms, on the clothing of handlers and in travel bags.

10.4.3.3 Thermedics System

This narcotics detector, known as Senter, is an adaptation of the Thermedics (USA) explosives 'sniffer,' which incorporates capillary column GC together with a sensor operating on the principle of chemiluminescence.

The system consists of an analyser unit mounted on wheels for portability and a detachable hand-held probe. The analyser unit contains a miniaturised GC column connected to a photomultiplier, an electrolytic carrier gas generator, a high-voltage discharge ozone generator and electronic and computing equipment. The probe houses a high-volume air pump, heat source and battery pack.

The surfaces of suspect items are scanned using the probe remote from the analyser unit. Heat from the probe promotes vaporisation of any organic material on the item and the vapours produced are collected on a metal ribbon within the probe. On completion of sampling, the probe is connected to the analyser unit, the coil is heated and the collected vapours are passed into the GC column. The column effluent passes through a catalytic pyrolyser, which produces nitric oxide from any organic nitrogen-containing compounds present. The nitric oxide so formed reacts with ozone in a low-pressure chamber according to the equation

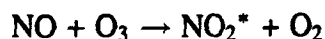

On decaying to the ground state, NO_2^* emits light in the near-IR region of the spectrum, and this is detected by the photomultiplier. Analysis for cocaine and heroin is completed within 30 s of interfacing the probe to the analyser unit.

Extensive field trials are being conducted in North America and the UK.

10.4.4 Ion Mobility Spectrometry

A narcotics detector based on GC analysis has been shown to be feasible and effective. Although in some circumstances, such as the spot checking of suspect

letter mail, the few minutes required to carry out the analysis may be acceptable, this time element represents a constraint on other uses. If operational constraints dictate a cycling period of less than a few minutes, then a real-time analyser should be considered. Ion mobility spectrometry (IMS) is a relatively new analytical technique that, despite some inherent shortcomings, can provide near real-time performance. Consequently, a research programme was initiated at NRC to investigate the feasibility of IMS as a viable technology for field use in the detection of narcotics and other drugs [9].

10.4.4.1 Principle of Operation

Ion mobility spectrometry (IMS), also known as plasma chromatography (PC), is an analytical technique that evolved from research conducted by Rutherford on the diffusion of ions. Rutherford found that gaseous ions drift through a gas in an electric field with a velocity proportional to the electric field strength. This proportionality constant has been termed the mobility of the ion (equation 10.2) and is defined as the drift velocity of an ionic species within a field of 1 V cm^{-1} in a gas at atmospheric pressure [10]:

$$V_d = KE \quad (10.2)$$

where V_d is the drift velocity, K is the ion mobility and E is the electric field strength. Progress in drift tube technology led to the development in 1971 of the ion mobility spectrometer as an ambient-pressure ionisation detector for trace organic detection and monitoring [10].

In IMS, the ions formed are separated according to their mobilities in a gas under an applied electrostatic field, and mobility spectra are obtained by measuring the time of flight of the ions as they drift through the field at atmospheric pressure. The basic components of the instrument include a heated inlet, an ionisation/reaction chamber, an ion drift chamber, a shutter grid interposed between the two chambers and an ion collector (Figure 10.5). A constant accelerating field is established along the length of the IMS cell, usually by means of a series of equally biased guard rings.

The conversion of gaseous molecules into ions can be achieved in a number of ways. Ionisation by energetic electrons from a radioactive foil source or corona discharge, laser multiphoton ionisation and photoionisation using a discharge lamp have all been reported. In chemical ionisation ion mobility spectrometry (CI-IMS), the sample, in vapour form, is introduced into the reaction chamber of the instrument by means of a carrier gas (nitrogen or air). Reactive trace impurities in the carrier gas, such as water and ammonia, are irradiated with electrons with a ^{63}Ni source, and a number of primary reactant ions are formed, e.g. $(\text{H}_2\text{O})_n\text{H}^+$ and $(\text{H}_2\text{O})_n\text{O}_2^-$. These ions transfer their charge through a series of complex ion-molecule reactions (analogous to those observed in chemical ionisation MS) to the

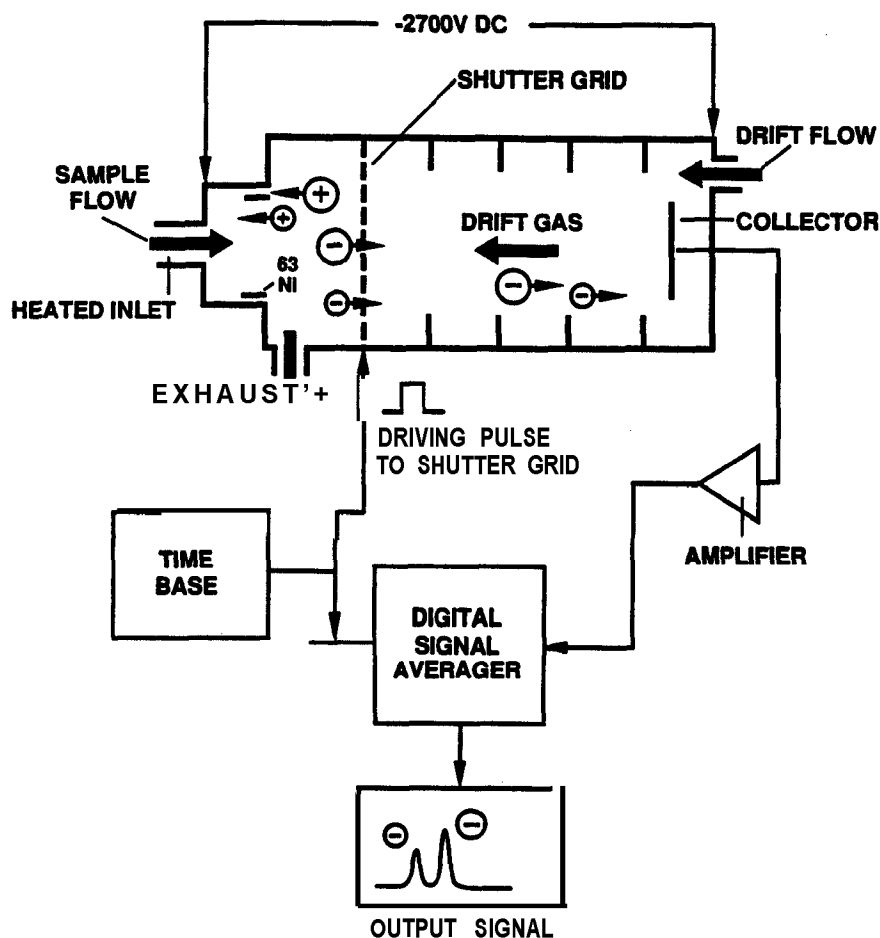

Figure 10.5. Schematic diagram of IMS

trace species of interest. In a typical IMS analysis a mixture of reactant and product ions (positively or negatively charged, depending on the polarity of the applied field) are periodically allowed to enter the drift chamber through the gated shutter grid. These ions are accelerated toward the collector against the countercurrent of a drift gas and separate into their individual chemical species as a result of their different mobilities. The drift time, t_d , of ionic species is a qualitative parameter that represents the time taken for a specific pulse of ions to arrive at the collector. The relationship between the drift time and the mobility of a particular ion is given by the equation

$$K = V_d/E = (l_d/t_d)E \quad (10.3)$$

where $K \text{ cm}^2 \text{ V}^{-1} \text{ s}^{-1}$, is the mobility, $l_d \text{ cm}$ is the drift length and $t_d \text{ s}$ is the drift time. Since the mobility, K , is dependent on the size of the ion and, to a lesser

extent, on its shape and charge distribution, mobilities are influenced by changes in the density of the drift gas. The effects of variable gas density can be removed by normalising the mobility against temperature and pressure according to the equation

$$K_0 = K(273/T)(P/760) \quad (10.4)$$

where K_0 $\text{cm}^2 \text{V}^{-1} \text{s}^{-1}$ is the reduced mobility, T K is the absolute temperature of the drift gas and P Torr is the atmospheric pressure. Consequently, reduced mobility constants are independent of the experimental conditions used and are a useful parameter for the identification of ionic species.

Drift spectra or ion mobility spectra are similar to gas chromatograms in appearance but not in principle. They trace the intensity of ion current as a function of time, and ion identification is based on known K_0 values. IMS may be considered to be similar to GC with electron-capture detection (ECD), inasmuch as both involve the time-related separation of a mixture followed by the detection of its ionised components. However, a fundamental difference is that ionisation in IMS takes place before, not after, the 'chromatographic' separation. In the IMS analysis of mixtures [11], the competitive nature of the ionisation process reduces the possibility of quantitative reproducibility from one experiment to another unless separation, for example by GC or HPLC, is carried out prior to IMS sample introduction. Further, ion mobility spectra offer no information about the mass of the ions associated with the peaks displayed therein. The time of flight of ions through the IMS is controlled not simply by atomic mass, but also by the number of collisions between the ionic species and the molecules of the drift gas. The mass associated with the spectral peaks must therefore be determined by an independent means in order to establish ion identities.

The obvious method for obtaining such ion mass information is to couple the IMS to a mass spectrometer. Existing IMS-MS technology and hardware are well advanced and relatively uncomplicated [10]. The mass identification of IMS peaks allows fundamental investigations into the plausibility of various ionic collision pathways and, more important, it establishes the existence of IMS signatures and fingerprints that permit the informed screening of samples in search of selected analytes.

In a strict theoretical interpretation, IMS can be considered to offer virtually infinite resolving power, in that it can separate isomers. In general, however, mobility-based separations are poorer than those which can be achieved with GC or MS, since the peak widths in IMS are ultimately diffusion limited [10]. Further, varying the experimental parameters controlling the IMS process, such as the strength of the electric field, does not have a significant effect on resolution [11]. However, resolution improvement can be achieved via post-separation electronic enhancement techniques. Second- and higher order derivative algorithms have been applied to IMS output signals in this laboratory, and peak separations down to 0.22 ms have been obtained [12]. Figure 10.6 shows the zero-order and corresponding

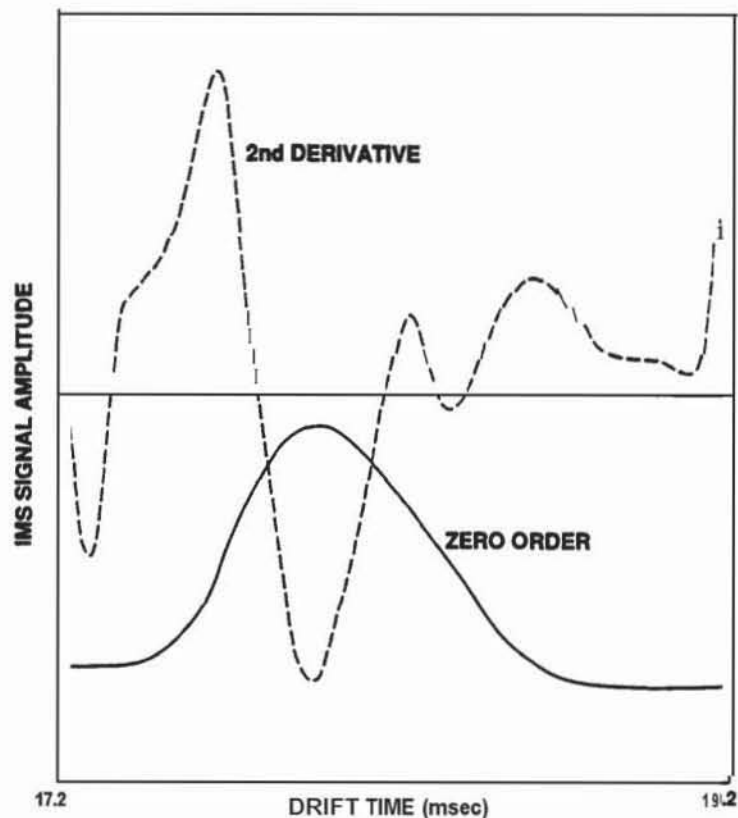

Figure 10.6. Zero-order and second-derivative ion mobility spectra of bromazepam and diazepam mixture

second-derivative output of an IMS signal of a mixture of bromazepam and diazepam.

The major advantages of IMS are its good sensitivity (sub-ppb), fast response time (0.1-10 s) and ease of operation. IMS is thus ideally suited for the initial screening and fingerprinting of samples in situations where time constraints dictate a short analysis cycle. Further, as IMS requires minimum sample preparation and operates at atmospheric pressure, it lends itself to miniaturisation and use in rapid, on-site chemical detection [13].

10.4.4.2 Determination of Ion Signatures

The IMS data presented in this chapter were obtained with a Phemto-Chem 100 ion mobility spectrometer (PCP), described elsewhere [9]. Although transportable, the instrument is designed for use as a fixed laboratory facility. As with the TND, all chemicals were introduced into the IMS by thermal desorption of sorbent tubes which could accommodate vapour, liquid or solid samples [14]. For calibration a 1 μl aliquot of the drug standard solution ($1 \times 10^{-8} \text{ g } \mu\text{l}^{-1}$ in methanol) is

deposited with a syringe on the sorbent material, and a gas stream of purified air is allowed to flow through the sample tube before the latter is inserted in the heated inlet of the instrument. On sample injection, the volatile chemicals evaporate and are transferred to the ion-reaction chamber for analysis.

As many illicit and prescription drugs contain nucleophilic secondary and tertiary amine groups, they have a relatively high gas-phase basicity and consequently capture an appreciable fraction of the positive charge available in the IMS. Some drug molecules possess both electropositive and electronegative characteristics, e.g. nitrazepam, and thus form both positive and negative ions in the IMS [15]. In general, chemicals with greater gas-phase basicity than water will often yield $[MH]^+$ ions through a proton transfer reaction between $(H_2O)_nH^+$ and M, as in the equation

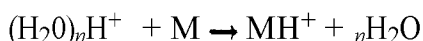

where M is the parent molecular species. Other chemicals fragment, forming inter *alia* $[M-H]^+$, $[M-2H]^+$, $[M-CH_3CO_2]^+$ and $[M-H_2O]^+$. It is desirable to minimise such fragmentation and to maximise $[MH]^+$ formation, as this ion provides valuable molecular weight information. In some cases, depending on the identity of M, fragmentation of the molecular ion occurs readily and is unavoidable. Nevertheless, advantageous structural information may be gained from these observed fragment ions and, together with the molecular ion, they can serve as markers or fingerprints of the chemicals of interest. Despite this, the majority of our experiments have not shown evidence of any appreciable fragmentation or ion cluster formation. Most compounds examined have produced a single main ion peak corresponding to M^+ or $[MH]^+$ ions [15,16].

10.4.4.3 Concealment Detection Applications

The suitability of IMS for the detection of narcotics has been investigated in both laboratory and field trials.

10.4.4.3.1 Letter mail screening Tests have been conducted in conjunction with Canada Customs on the application of IMS to the detection of drugs in letter mail. Five letters, one ‘innocent’ and four suspected of containing drugs, were examined using an adsorber/filter cartridge in conjunction with a hand-held suction pump to collect drug microparticles [17]. Strong IMS signals characteristic of heroin or tetrahydrocannabinol (THC) were obtained from the four suspect letters, whereas no signal was recorded for the innocent letter. The ion mobility spectra yielded strong, characteristic peaks for the drugs in question and there was no interference from the packaging material. Figure 10.7 shows the plasmagrams derived from the letter containing THC.

10.4.4.3.2 Baggage screening Tests have been conducted to assess the effectiveness of IMS in the detection of drugs concealed in baggage. In simulated

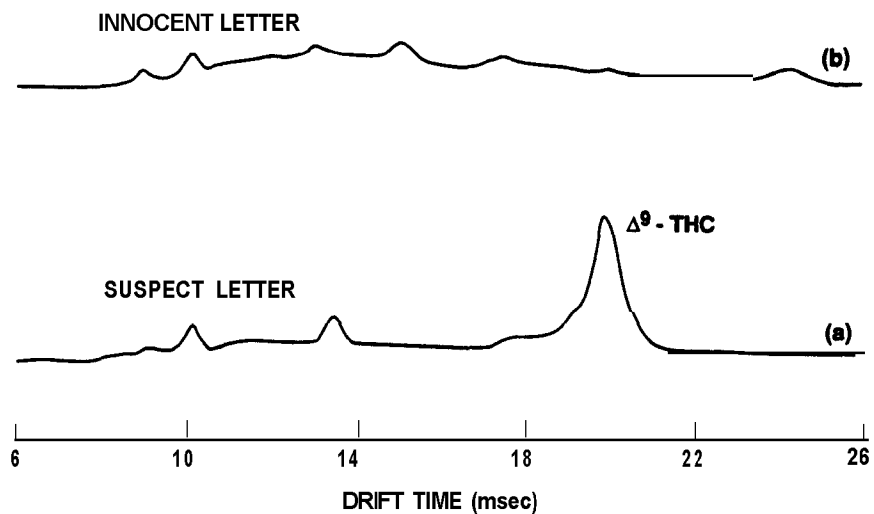

Figure 10.7. Ion mobility spectra (plasmagrams) from sampling letters

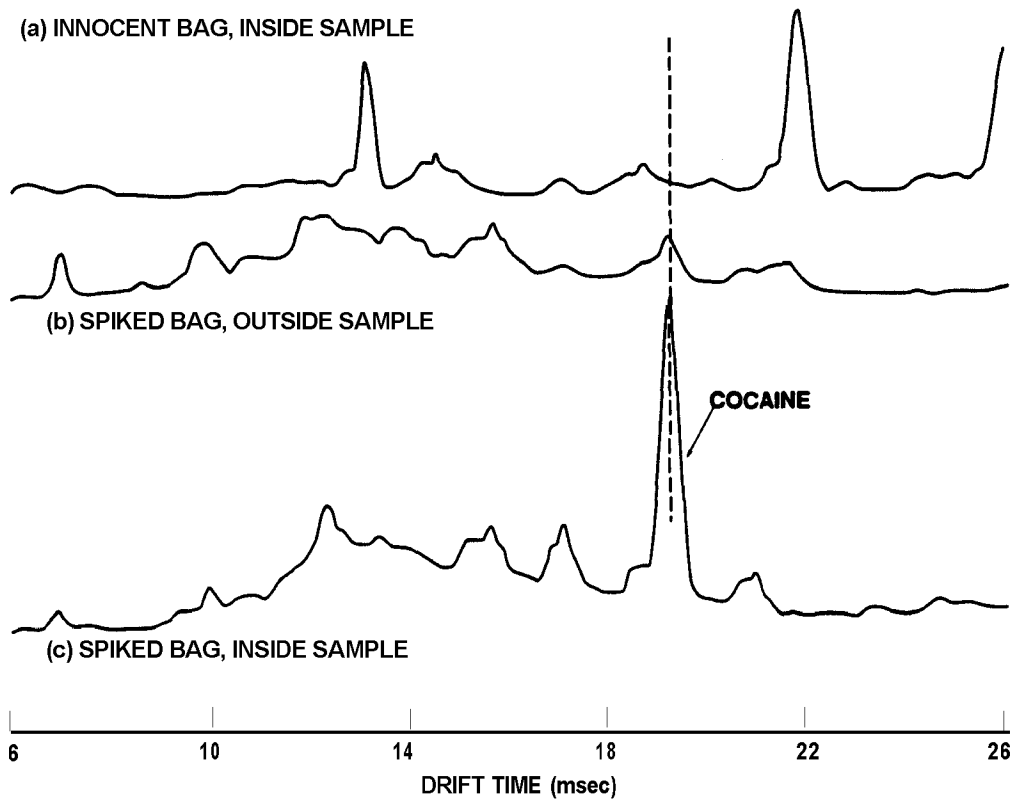

Figure 10.8. Ion mobility spectra from sampling baggage

concealments, cocaine was easily detectable on both the inside and outside of suitcases (Figure 10.8).

In trials at an airport, suspect baggage was sampled using the adsorber/filter cartridge method. No drugs were discovered by IMS (or TND), but some valuable information was obtained on interfering compounds and memory effects. The IMS-based instrument gave no false-positive responses and had a faster system recovery time than the TND.

10.4.4.4 Medical and Health Applications

Forensic medicine makes use of a variety of instrumental techniques to detect trace amounts of drugs and poisons present in various circumstances. Laboratory methods can be time consuming, and there does not yet exist a versatile, rapid, on-site method for characterising selected chemicals of interest based on a single analysis.

The potential of IMS has been investigated with regard to the detection of drug residues on the hands of subjects [14]. The initial study was carried out under controlled laboratory conditions using pharmaceutical tablets (acetaminophen 325 mg, amitriptyline 50 mg, codeine 15 mg, nitroglycerin 600 mg and diazepam 5 mg) and cannabis resin. After normal handling the surface of the hands was sampled with the adsorber/filter cartridge probe. Distinct IMS signatures were obtained for these and other drugs. The effect of subsequent activities, such as washing, on the level of contamination has also been studied.

Tests have also been conducted in a hospital [18] to determine which contaminants, if any, present in an emergency ward would interfere with the IMS toxicological screening of emergency patients suspected of drug overdose. Pharmaceutical tablets of acetaminophen (325 mg), acetylsalicylic acid (325 mg), amitriptyline (10 mg), clorazepate (15 mg), codeine (15 mg), diazepam (5 mg), dimenhydrinate (50 mg), imipramine (25 mg) and phenobarbitone (15 mg) were used. The drugs were handled normally prior to sampling the skin of the 'patient.' All gave rise to spectra with reduced mobilities (K_0) in the range $1.0\text{--}2.0\text{ cm}^2\text{ V}^{-1}\text{ s}^{-1}$. Storage of samples for up to 3 days following collection did not give rise to inferior spectra. Samples were also taken from the hands of emergency nursing staff at the end of their shifts, but who had not handled these drugs. In almost all cases, a distinct IMS signature was obtained with two major peaks at $K_0 = 1.11$ and $1.20\text{ cm}^2\text{ V}^{-1}\text{ s}^{-1}$. These represented the quasi-molecular ion and fragment of a chemical in the hospital liquid hand cleaner. No other compounds possessed such potentially interfering reduced ion mobilities.

IMS has also been evaluated in a real hospital situation [19]. All admitted emergency room patients with a history of drug overdose and who consented to be involved had their palms, fingers and nostrils sampled. Whenever possible, blood and urine samples were also obtained to confirm IMS findings using standard hospital laboratory tests. For each patient, the time elapsed between admission and

sampling was recorded, as was the form (i.e. capsule, powder, tablet, etc.) in which each medication had been ingested. Drug verification was through reference to pure drug standards, and the mass identities of those ions yielding mobility peaks of interest were confirmed in a separate series of IMS-MS experiments. Figure 10.9, for example, shows the IMS identification of the tricyclic antidepressant doxepin on the hands of a patient whose blood serum was later proved to be positive for this type of compound. The IMS responded favourably in this series, with a high identification rate being achieved for the uncoated tablets. Traces of drugs from the coated tablets and capsules proved to be the most difficult to detect. Of the known cocaine ingestions, all were detected. These experiments indicate that IMS can have a useful role for screening patients where the abuse of drugs is implicated.

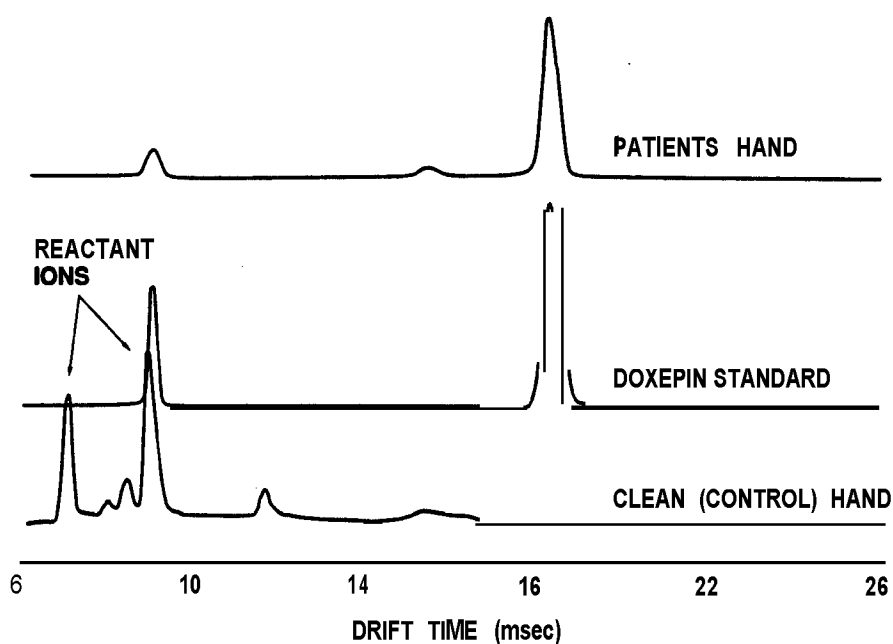

Figure 10.9. Ion mobility spectra from sampling hands

10.4.4.5 Barringer System

Several companies in Canada have undertaken the commercial development of IMS-based detectors. One such device for field use, the Barringer Ionscan, is described below.

The Ionscan provides on-line and remote sample collection. In the former, a high-volume air stream ($> 1000 \text{ l min}^{-1}$) is drawn through a flexible vacuum hose and cyclone particle separator. Particulates are removed from the air stream and collected at the base of the cyclone on porous PTFE tape housed in a cassette style holder. The segment of the tape containing sample is then reeled into the inlet

port of the IMS, where a contact heater rapidly vaporises the particles. The drift tube can operate at temperatures up to 300 °C. In the remote sampling mode, a discrete filter disc is used in a hand sampler. Following sampling it is removed and inserted into the inlet port for analysis. Although more time consuming, the latter method avoids the problem of dust build-up in the cyclone and is the more reliable sampling approach.

The Ionscan has been field tested in the following customs related situations:

- (i) Screening mail at postal facilities. A total of 650 letters and small parcels were examined at two different locations, of which 290 were opened for confirmation. No false negatives or positives for cocaine and one false positive for heroin were recorded. Control parcels spiked with the drugs were correctly identified.
- (ii) Checking incoming cargo at the dockside. In simulation tests, some success was achieved in identifying cargo items containing narcotics.
- (iii) Screening vehicles and their occupants at border crossings. In one set of trials, 28 suspect cars were examined with the Ionscan. Traces of cocaine were detected on the seats, door handles and the steering wheels of six of the cars, although a manual search uncovered no cocaine. In most of the cases drug detector dogs also indicated the presence of narcotics. Of 24 people tested, four had traces of cocaine on their hands.

Work is in progress in conjunction with NRC and Canada Customs to improve the Ionscan, particularly in respect of sample acquisition and signal conditioning.

10.5 CONCLUSIONS

The vapour pressures of narcotics are so low as to make detection difficult in typical search situations, while volatile by-products of their manufacture are too common to provide a sufficiently distinctive chemical signature.

Particles, unlike vapours, do not diffuse, but can be transferred to the outer surface of their container as a result of handling during the packaging process. When such external contamination occurs, the amount of material available for detection is often greater than that which can be provided by a diffusive vapour plume.

Whereas microscopic amounts of narcotic particles on the exterior of a package are readily detectable with existing chemical 'sniffing' techniques, the collection of this material for analysis requires contact of the sampling probe (whether suction or swab type) with the surface.

Locating concealed drugs on the basis of residue detection is less reliable than for explosives because of the high background levels generated by the proliferation of narcotics in public places.

Prevailing high background levels of narcotics residues could render the

development of new technology having enhanced *sensitivity* redundant. A more productive approach could be to look for improvements in *selectivity* through simple, fast clean-up procedures.

Trace chemical detection technology is not seen to be a viable approach to the routine screening either of whole cargo containers by very high-volume sampling or of individual cargo items by exterior surface sampling, that is, without access to the interior of the items and their contents.

Trace chemical detectors in drug interdiction may be better suited to the role of field analysers, as in the case of suspect letter mail or other items which can be removed from the mainstream and intimately sampled. Other examples could include the testing of suspect beverages and foodstuffs, carpets and fabrics.

Detectors could play a useful role in obtaining preliminary evidence of drug concealment or handling in vehicles and dwellings. Detectors may also be used to advantage as a rapid screening aid in forensic and medical diagnostic applications.

Detector dogs, despite their disadvantages, can play a very important role in drug interdiction, from both a public relations/deterrence aspect and detection capability. It may be possible to improve their effectiveness through training with 'weaker' sources and hides, in a similar manner to that observed with explosives sniffing dogs.

ACKNOWLEDGEMENTS

The authors gratefully acknowledge the financial support of Canada Customs, the Canadian Police Research Centre and the Ontario Ministry of Health.

REFERENCES

- [1] J.G. Arnold (ed.), *Technical Aids for Illicit Drug Detection*, LTR-PSP-16, National Research Council, Ottawa, 1985, (limited distribution).
- [2] L. Elias, *J Chromatogr. Sci.* 13, 178 (1975).
- [3] L. Elias, M. McCooeye and G. Gardner, *Geophys. Res. Lett.* 3(1), 17 (1976).
- [4] L. Elias, *Development of a Portable Gas Chromatograph Explosives Detector* LTR-UA-57, National Research Council, Ottawa, 1981, (limited distribution).
- [5] A.H. Lawrence, L. Elias and M. Authier-Martin, *Can. J. Chem.* 62, 1886 (1984).
- [6] A.H. Lawrence and L. Elias, *Am. Lab.* 21, 88 (1989).
- [7] L. Elias and A.H. Lawrence, *Can. J. Spectrosc.* 32, 14A (1987).
- [8] A.H. Lawrence and L. Elias, *Screening of Letter Mail for Cocaine and Heroin by Air Sampling and GC Analysis*, LTR-UA-85, National Research Council, Ottawa, 1986 (limited distribution).
- [9] A.H. Lawrence and L. Elias, *Bull. Narc.* 37(1), 3 (1985).
- [10] T.W. Carr (ed.) *Plasma Chromatography*, Plenum Press, New York, 1984.
- [11] A.H. Lawrence and P. Neudorfl, *Anal. Chem.* 60, 104 (1988).
- [12] R.A. Goubran and A.H. Lawrence, *Int. J. Mass Spectrom. Ion Processes*, in press.

- [13] J.P. Carrico, A.W. Davis, D.N. Campbell, J.E. Roehl, G.R. Sima, G.E. Spangler, K.N. Vora and R.J. White, *Am. Lab.* 18, 152 (1988).
- [14] A.H. Lawrence, *Forensic Sci. Int.* 34, 73 (1987).
- [15] A.H. Lawrence, *Anal. Chem.* 61, 343 (1989).
- [16] A.H. Lawrence, *Anal. Chem.* 58, 1269 (1986).
- [17] A.H. Lawrence, L. Elias and G. Turcotte, *Detection of Narcotics in Letter Mail: Actual Case Incident*, LM-UA-207, National Research Council, Ottawa, 1985 (limited distribution).
- [18] A.H. Lawrence, A.A. Nanji and J. Taverner, *J. Clin. Lab. Anal.* 2, 101 (1988).
- [19] A.A. Nanji, A.H. Lawrence and N.Z. Mikhael, *J. Toxicol. Clin. Toxicol.* 25,501 (1987).